

## Achieving Optimum Scientific Standards for Producing Fabrics Suitable for Protecting Against Hazardous Chemical Liquids

Ibrahim, G. E.;<sup>1</sup> Abdel-motaleb A.F.<sup>2</sup> and Mahmoud, E.R.<sup>3</sup>.

<sup>1</sup> Faculty of Education – Zilfi, AL-Majma'ah University

<sup>2,3</sup> Spinning, Weaving and Knitting Department, Faculty of Applied Arts, Helwan University, Egypt  
g.selem@mu.edu.sa

**Abstract:** Occupational exposure of the skin to toxic chemicals is a recognized health problem so chemical protective clothing is considered the most important line of defense to the worker who is exposed to the hazardous chemicals. This research aims to produce fabrics suitable for protecting against hazardous liquids (accidental splashes of chemicals). All samples under study were produced cotton and cotton /polyester 50/50 .Three weft sets were used 24, 27 and 30 picks /cm and three fabric structure (plain weave 1/1, twill 2/2 and satin 4). Samples were coated, on one face, with transol F L 20 to make the fabric repellent and a barrier to Protect against hazardous chemical liquids .Their influence on the performance of the end-use fabric and the achieved properties were studied. On the other hand physic-chemical properties including, tensile strength and elongation, studying the effect of some hazardous liquids chemicals using Gutter method, tensile strength and elongation, water absorption, roughness, thickness and weight were evaluated according to the final product needs. Some more results were reached concerning structures and materials. Most samples have achieved the expected results.

[Ibrahim, G. E.; Abdel-Motaleb A. F and Mahmoud E. R **Achieving Optimum Scientific Standards for Producing Fabrics Suitable for Protecting Against Hazardous Chemical Liquids** ] Life Science Journal 2012;9(x):-]. (ISSN: 1545-1003). <http://www.lifesciencesite.com>

**Key Words:** Protective textiles - chemical protective clothing (CPC) - coated fabrics - breathable coated fabrics

### 1. Introduction

Modern technological developments have brought with them a multifold increase in Safety and protective textiles have become an integral part of technical textiles (1). These textiles are designed to protect the wearer from harsh environmental effects that may cause injury or may turn out to be fetal (2,3) . It may also be necessary to protect the environment from people as in the case of clean rooms (3) .

The nature of a hazard to the health and safety of the workers can be uniquely different. Nevertheless, workplace hazards can be grouped in the following categories: chemical, thermal, mechanical, nuclear (radiation) and biological hazards (4) .

Protective clothing provides laboratory and hazardous materials workers , firefighters , military personnel, farmers, truck drivers of toxic /flammable materials and others with the means to control their exposure to chemicals, biological materials and heat sources (5) , so these fabrics have to meet high standards of quality and offer protection against seriously health-endangering or life threatening occupational risks (6) .

There are many factors to consider when selecting a protective garment including type of application, level of protection, type of chemicals, breathability, productivity, cost, acceptance and durability (3,5) .

### Chemical Protective Clothing (CPC)

Occupational exposure of the skin to toxic chemicals, during both routine and emergency chemical handling, is a recognized health problem,

as it is estimated that more than 100.000 chemical products with very different toxicological properties are in use throughout the world (7).

Chemical hazards from liquids ( which are the main concern of this research ),gases , or dust occurring in sector such as fertilizers , electroplating, and the pharmaceutical industry, these hazards necessitate the wearing of clothing that is impermeable , is resistant to acids , and provides a tight seal against toxic gases, micro-organisms ,or bacteriological hazards requiring antimicrobial fabrics (1) .

Selection of CPC is a complex task, and the consequence of making wrong selections can vary from a skin rash to a life-threatening situation (7).

### Types of chemical protective clothing

Coated fabrics play a key role in both civil and military applications as far as protection for the whole body is concerned (9). Products used for chemical protection range from simple coveralls, gloves , boots , face shield and aprons to the use of highly sophisticated systems such as totally encapsulating suits which provide a gas-tight envelope around the wearer (3,8) .

Chemical protective clothing is customarily classified as durable and disposable. Durable CPC can be used many times but may need decontamination treatments between uses. This type is usually made of woven or knitted fabrics and is coated. Disposable CPC is made of nonwovens and can be used only once (3) .

The protective coated fabrics used for protection of the human body may also be conveniently classified in two broad categories,

permeable or breathable and impermeable or non-breathable. As the names suggest, the former allows free ingress and egress of air facilitating the dissipation of heat and evaporation of sweat, while the latter completely shields the wearer from the atmosphere. Obviously, the devices made of permeable-type fabrics can be used for longer duration of time due to comparatively low heat stress. However, for many applications where large quantities of toxic chemicals are handled or liquid splash may occur completely drenching the wearer, impermeable suits are preferred (9).

### Protection against hazardous liquids

The most common cause of injury among chemical workers in factories, laboratories ...etc. is penetration of liquids chemicals, such as acids and other corrosive chemicals, through their clothing due to spillage, so chemical protective clothing is considered the most important line of defense to the worker who is exposed to these hazardous chemicals (1, 7).

### Penetration theory

Permeation is the molecular process by which chemicals move through protective clothing materials. The mechanism of permeation involves three steps: (1) absorption of individual molecules of the chemical into the exposed surface of the material (2) , molecular diffusion through the material matrix(3) and desorption of the chemical from the inside surface (7,10) .

### Coated breathable protective clothing

In the last few years, the diversity of waterproof, water vapor fabrics has grown with the reinforcement of coating and laminating techniques. Surface coatings are applied to porous fibrous fabrics to prevent the penetration of hazardous liquids, gases, and particles to the wearer (11) .Wicking is the most common way to prevent the transport of liquid through fabrics , as wicking materials are hydrophilic in that a drop of liquid placed on the surface of these materials form an advancing water contact angle of less than 90 degrees so that they wet spontaneously (12) .

In order to achieve comfort, these fabrics should also be breathable. Breathability is achieved by permitting moisture vapor such as perspiration to pass out through it(13), by capillary action from interior surface to exterior surface where it evaporates (11) .

### 2. Experimental work

This research concerns with producing fabrics suitable for protective clothing against hazardous chemical liquids. All samples in the research were produced with woven technique with 100% cotton and 50/50 cotton /polyester blend using three woven structures (plain weave 1/1, twill 2/2 and satin 4) and three weft sets were also used (24,27 and 30 picks).

**Table (1)** specifications of all samples, produced in this research

No.	Fabric structure	Yarn type		Yarn set	
		Warp	Weft	Warp	Weft
1	Satin 4	Cotton	Cotton	36	24
2	Satin 4	Cotton	Cotton	36	27
3	Satin 4	Cotton	Cotton	36	30
4	Twill 2/2	Cotton	Cotton	36	24
5	Twill 2/2	Cotton	Cotton	36	27
6	Twill 2/2	Cotton	Cotton	36	30
7	Plain weave 1/1	Cotton	Cotton	36	24
8	Plain weave 1/1	Cotton	Cotton	36	27
9	Plain weave 1/1	Cotton	Cotton	36	30
10	Satin 4	Cotton	Cotton /polyester	36	24
11	Satin 4	Cotton	Cotton /polyester	36	27
12	Satin 4	Cotton	Cotton /polyester	36	30
13	Twill 2/2	Cotton	Cotton /polyester	36	24
14	Twill 2/2	Cotton	Cotton /polyester	36	27
15	Twill 2/2	Cotton	Cotton /polyester	36	30
16	Plain weave 1/1	Cotton	Cotton /polyester	36	24
17	Plain weave 1/1	Cotton	Cotton /polyester	36	27
18	Plain weave 1/1	Cotton	Cotton /polyester	36	30

## Finishing treatment

The produced fabrics were undergoing special treatments before being used as they were treated with transol F L 20 to make the fabric repellent and barrier to some hazardous chemical liquids, as follow: , Samples were treated using solution containing The

### Gutter test method used for measuring repellency, retention, and penetration of liquid chemicals through protective clothing

#### Procedures

The test assembly consisted of a 36.0 X 23.5 cm fabric specimen (top layer) and a 360 X 235 mm cellulose paper backed with plastic film (Benchkote), the collector layer. Both layers were folded 30 mm from each end along the length and placed over the collector layer. Both layers were weighed separately prior to testing. The test assembly was clipped to the 45° inclined gutter, ensuring that the top edge of the test assembly was aligned with the top edge of the gutter and the bottom edge protruded 30 mm from the bottom edge of the gutter. A preweighed plastic beaker with a screw top was weighed and placed under the gutter to collect the pesticide running off the fabric surface. A syringe with a hypodermic needle was used to apply 10 ml of chemical solution (20 % NaOH, 70 % HNO<sub>3</sub>) in the form of a jet, to the surface of the fabric in 10 seconds. The distance between the needle tip and the fabric was 100 mm. A rigid semicircular cover was then held against the surface of the test specimen for 60 seconds to ensure contact between the

#### Tests

Several tests were carried out in order to evaluate the produced fabrics, these tests were:-

- 1- Gutter test method used for measuring repellency, retention, and penetration of liquid chemicals ,performance has been determined according to The ISO 6350/EN368 gutter method <sup>(14)</sup> .
- 2-Roughness, this test was measured according to AATCC standard test method using a Surfacer (1700a) <sup>(15)</sup> .

## Results and Discussion

### Protection characteristic after treatments (Measuring repellency, retention, and penetration of liquid chemicals)

#### Before treatment

All Samples showed no protection before treatments as we can notice from results that untreated fabrics did not provide any resistance against hazardous chemical liquids .Treatment of fabrics led to improvement in properties of samples against hazardous chemical liquids.

#### After treatment

Table (2) show protection characteristic of all samples under study after treatments by measuring

procedures were 20-50 g/l of transol F L 20 at PH 4-8 and then squeezed to 40 - 70 % wet pick up. The fabric samples were dried at 100 - 120<sup>0</sup>C for 2 sec., and thermo-fixed at 150 -160 <sup>0</sup>C for polyester and180 <sup>0</sup>C for cotton for 40 sec.

top and the collector layer. Chemicals that not retained by that assembly was collected in the beaker. After the test was completed, the layers of the test assembly were separated and weighed separately. The weight gain in the fabric measured chemical retained and the amount in the collector measured penetration. The amount collected in the beaker was used to calculate repellency. There were six replications for this test method.

We used the following formulas to calculate the percent (indices) of repellency, penetration, and chemical retained (absorption). Although not required by the test method, we calculated the percent pesticide retained (absorption) so that we could compare the results with the other methods.

$$\text{Percent penetration} = \text{Mp} \times 100/\text{Mt}$$

$$\text{Percent repellency} = \text{Mr} \times 100/\text{Mt}$$

$$\text{Percent retention} = \text{Ma} \times 100/\text{Mt}$$

where Mt= mass of chemical discharged on the test fabric (total amount applied), Mp = mass of chemicals deposited on the polyethylene backed absorbent paper,

Mr , = mass of chemical collected in the beaker, and Ma = mass of chemical in the test specimen

- 3- Water absorption, this test was carried out according to the ISO 811: 1981<sup>(16)</sup> this test was applied on the non treated face .
- 4- The tensile strength and elongation at break, this test was carried out according to the (ASTM-D1682) <sup>(17)</sup>
- 5-Fabric thickness, this test was carried out according to the (ASTM-D1777/1996) <sup>(18)</sup>
- 6-Fabric weight, this test was carried out according to the ASTM-D 3776- 79 <sup>(19)</sup>

repellency, retention, and penetration of liquid chemicals according to gutter method

It is clear from the diagrams that the cotton samples had increased protection against hazardous chemical liquids than cotton/polyester blend samples. We can state that cellulose samples have absorbed the treatment material more than the blended samples.

It is also obvious from the results that, samples of 24 picks/cm , have achieved the highest rates of protection against hazardous chemical liquids ,whereas samples produced 30 picks/cm has achieved the lowest rates ,this is due to the increases of picks/cm increase fabric compactness leading to decrease in its absorption of the treatment material leading to the

decrease in its protection against hazardous chemical liquids used in the research.

It is clear from the diagrams that satin weave have achieved the highest rates of protection against hazardous chemical liquids followed by twill weave and then plain weave 1/1. This is probably because

satin structure have the advantage of containing long floats and less intersections and so the treatment solution can easily permeate into the fabric (easily absorbed) compared to plain weave structure which has more intersections.

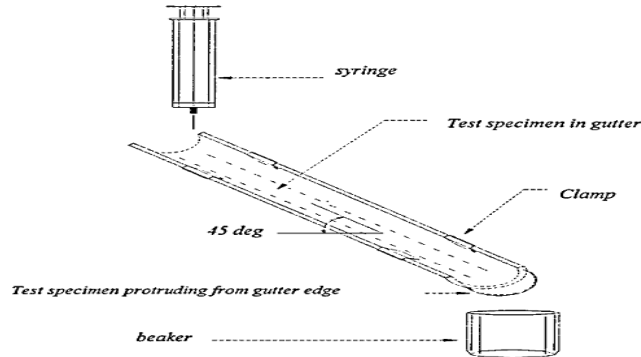
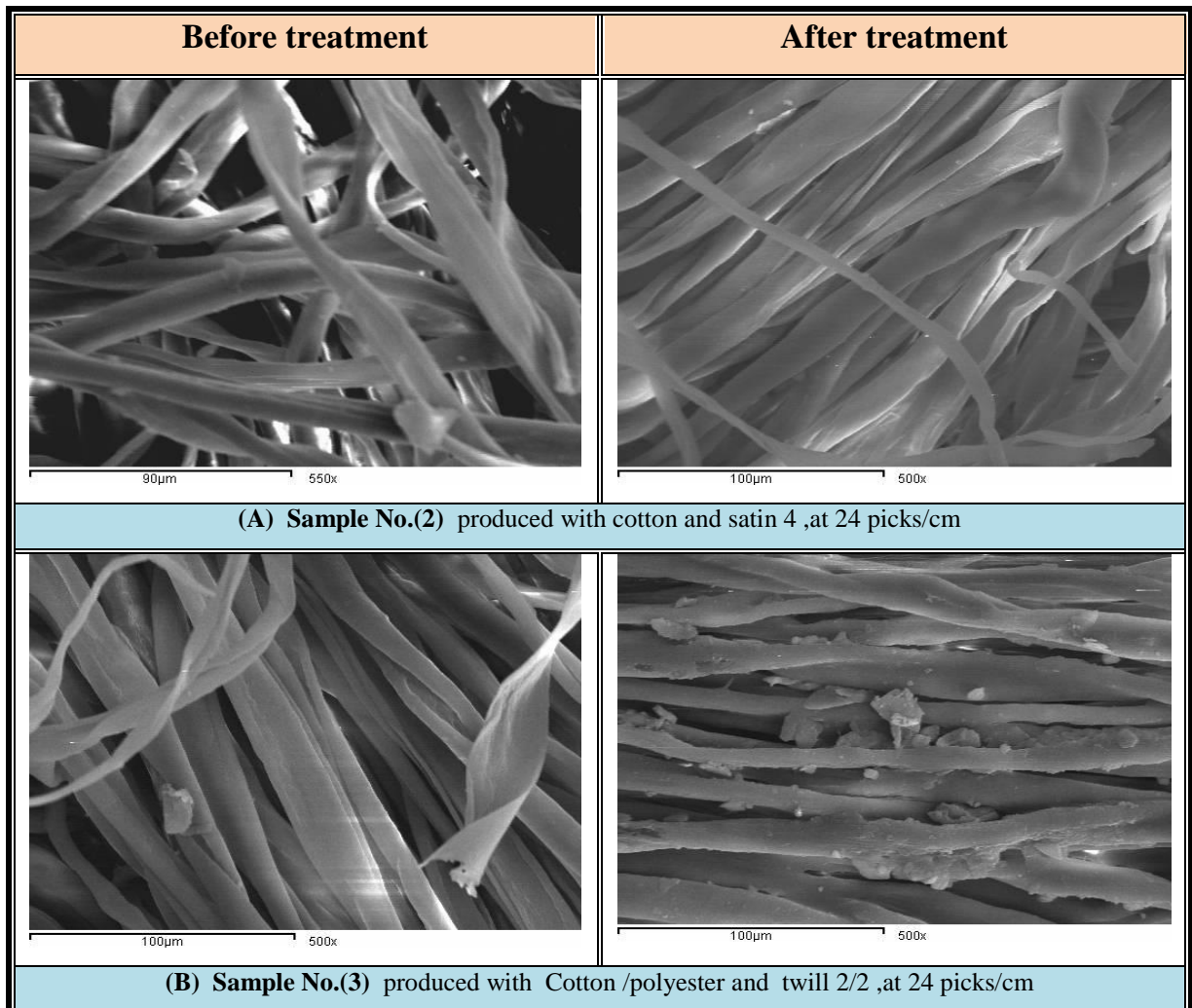
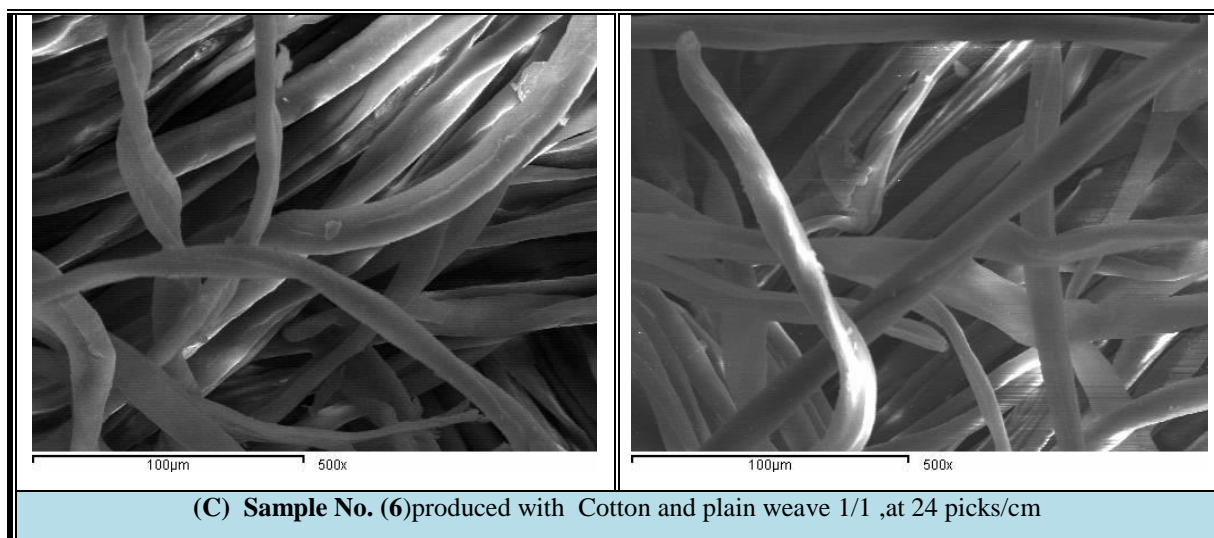

FIGURE 1. Gutter test apparatus.





**Fig. (2)** Scanning electron micrograph (SEM) of different cotton fabrics before and after treatment .

**Table (2)** Protection characteristic after treatments for all samples.

	Protection characteristic after treatments					
	NaOH (20 %)			HNO <sub>3</sub> (70 %)		
	Repellency %	Retention %	Penetration %	Repellency %	Retention %	Penetration %
1	99.4	0.66	0.16	99.7	0.26	0.04
2	99.5	0.59	0.09	99.4	0.49	0.11
3	99.7	0.64	0.34	99.7	0.24	0.06
4	98.9	0.86	0.24	99.6	0.26	0.14
5	99.2	0.65	0.15	99.8	0.21	0.01
6	99.3	0.68	0.02	99.8	0.18	0.02
7	98.6	0.61	0.30	99.4	0.37	0.05
8	99.1	0.64	0.09	99.5	0.25	0.07
9	99.3	0.55	0.04	99.6	0.29	0.05
10	99.1	0.61	0.29	99.6	0.36	0.04
11	99.3	0.63	0.07	99.7	0.23	0.07
12	99.4	0.57	0.03	99.7	0.27	0.03
13	98.7	0.88	0.22	99.4	0.38	0.22
14	99.1	0.60	0.3	99.6	0.35	0.05
15	99.2	0.75	0.05	99.7	0.25	0.05
16	98.6	0.91	0.24	99.2	0.36	0.24
17	99.0	0.65	0.5	99.5	0.33	0.06
18	99.2	0.59	0.05	99.4	0.25	0.05

### Tensile strength and elongation

It is obvious from the results obtained that plain weave has recorded the highest rates of tensile strength and lowest rates of elongation compared to twill and satin weaves. This may be due to that plain weave has more intersections than twill and satin weaves which decreases yarns slippage ability and so increase its tensile strength and decrease its elongation.

It is clear from figures that there is a direct relationship between number of picks /cm and fabrics tensile strength, This is mainly because of that the increase of picks means an increase in the number of fibers per unit area and so the contact areas between fibers will be increased and its

resistance to slippage will also be increased leading to the increase in fabric strength ,so samples of 30 picks /cm have recorded the highest rates of tensile strength, whereas samples with 24 picks/cm have recorded the lowest rates of tensile strength.

It is also obvious from the results that treated samples have achieved higher tensile strength and lower elongation compared to non-treated samples. This is due to the strike – through of coating composition through the interstices of the fabric leading to the decrease in spaces between yarns and so the fabrics become more compacted, and thus increase fabric tensile strength and decrease elongation.

**Table (3)** results of tensile strength and elongation test applied to produced samples

The test No .	Tensile strength (Kg)		Elongation (%)	
	Before treatment	After treatment	Before treatment	After treatment
1	35.5	40.2	13.58	12.42
2	64.44	75.39	10.83	9.83
3	103.10	111.1	8.66	8.5
4	36.28	42.2	11.42	10.92
5	83.04	90.22	10.17	9.75
6	110.9	118.2	8.02	7.91
7	38.13	43.23	10.92	10.17
8	82.39	97.11	9.58	9.5
9	126.1	136.4	7.91	7.75
10	46.25	52.98	12.5	11.0
11	88.59	96.79	10.42	9.56
12	122.5	125.4	8.25	8.08
13	63.38	74.6	10.83	11.67
14	93.3	97.08	10.01	9.66
15	126.30	128.1	8.0	7.83
16	64.04	74.73	10.58	9.16
17	93.77	101.9	9.00	8.67
18	128.4	134.3	8.00	8.25

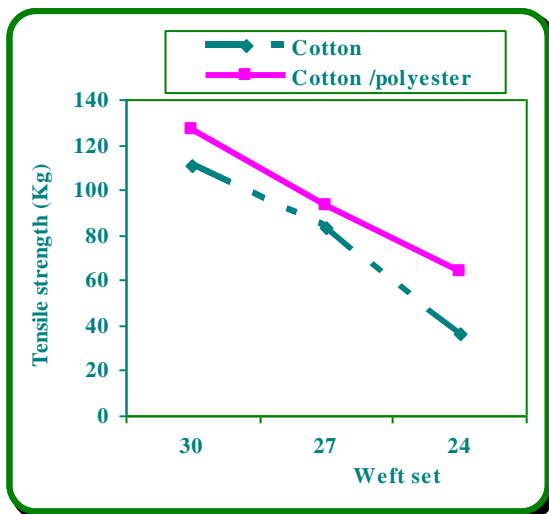

Fig.(3) effect of fiber type and weft set on tensile strength, at twill 2/2 before treatment

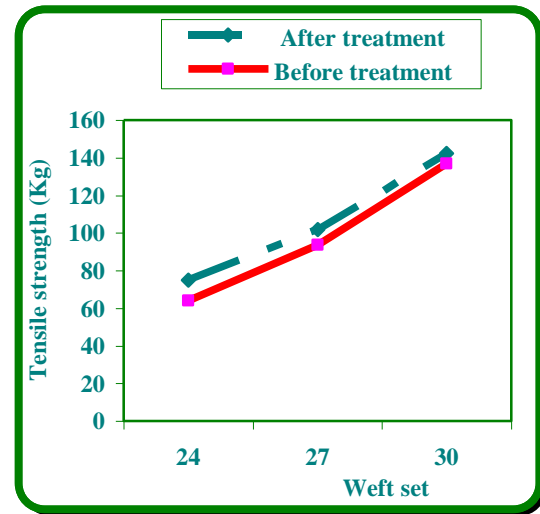

Fig.(4) effect of weft set on tensile strength, at 50/50 cotton/polyester blend samples and plain weave 1/1, after and before treatment

**Table (4)** Regression equation and correlation coefficient for the effect of weft set on tensile strength, at twill 2/2 after and before treatment.

The variable	Regression equation	Correlation coefficient
After treatment	$Y=11.2783X-198.172$	-0.993595
Before treatment	$Y=15.52833X-327.018$	-0.995938

**Table (5)** Regression equation and correlation coefficient for the effect of weft set on tensile strength, at 50/50 cotton/polyester blend samples and plain weave 1/1 after and before treatment.

The variable	Regression equation	Correlation coefficient
After treatment	$Y=11.2783X-198.172$	-0.993595
Before treatment	$Y=12.14333X-229.633$	-0.99441

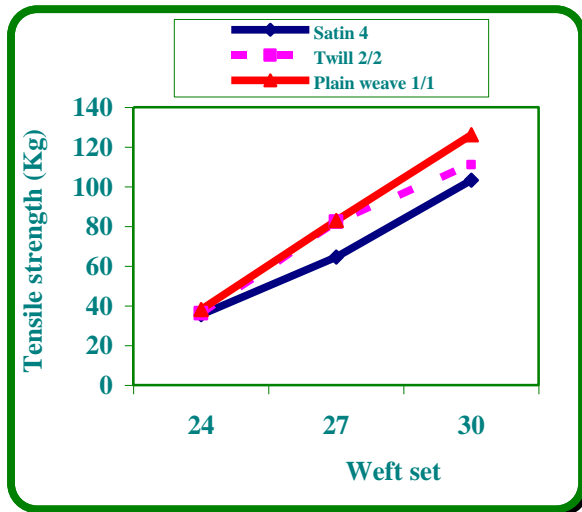

Fig.(5) effect of weft set and fabric structure on tensile strength, at 50/50 cotton/polyester blend samples, after treatment

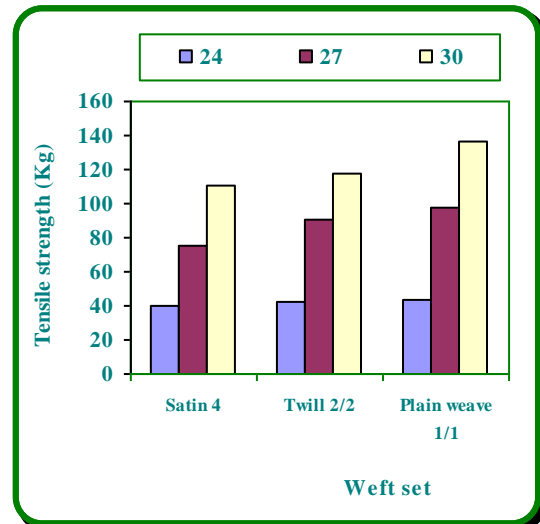

Fig.(6) effect of weft set and fabric structure on tensile strength, at cotton samples, after treatment

**Table (6)** Regression equation and correlation coefficient for the effect of weft set and fabric structure on tensile strength, at 50/50 cotton/polyester blend samples, after treatment.

Fabric structure	Regression equation	Correlation coefficient
Plain weave 1/1	$Y=14.66167X-313.442$	-0.999926
Twill 2/2	$Y=12.43667X-259.267$	-0.990855
Satin 4	$Y=11.26667X-236.52$	-0.996572

**Table (7)** Regression equation and correlation coefficient for the effect of weft set and fabric structure on tensile strength, at cotton samples after treatment.

Fabric structure	Regression equation	Correlation coefficient
Plain weave 1/1	$Y=15.52833X-327.018$	-0.99538
Twill 2/2	$Y=12.6667X-258.46$	-0.98804
Satin 4	$Y=11.81667X-243.487$	-0.999991

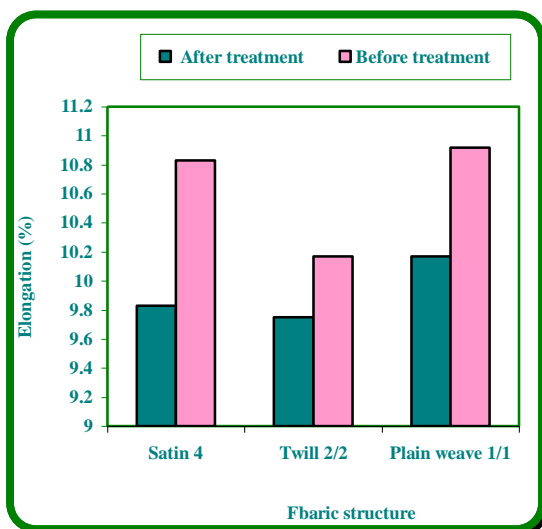

Fig.(7) effect of fabric structure on elongation, at 27 picks/cm and cotton samples, after and before treatment

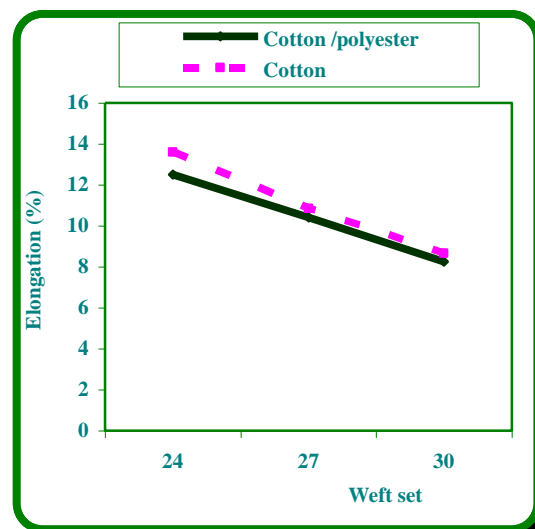
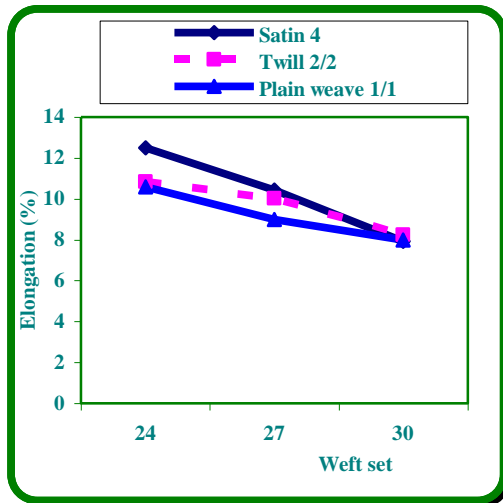
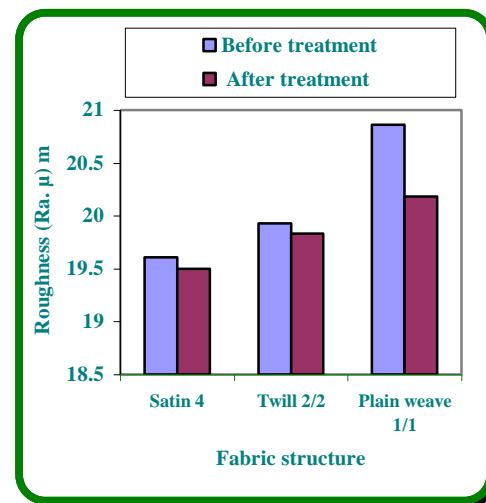

Fig.(8) effect of fiber type and weft set on elongation, at satin 4 before and after treatment

**Table (8)** Regression equation and correlation coefficient for the effect of weft set on elongation, at satin 4, after treatment.

Fiber type	Regression equation	Correlation coefficient
Cotton	$Y = -0.82X + 33.16333$	-0.997692
Cotton /polyester 50/50	$Y = -0.708333X + 29.515$	-0.999925

**Fig.(9)** effect of fabric structure and weft set on elongation, at 50/50 cotton/polyester blend samples, before treatment**Fig.(10)** Effect of fabric structure on roughness, at 50/50 cotton/polyester blend samples and 30 picks/cm before and after treatment**Table (9)** Regression equation and correlation coefficient for the effect of weft set on elongation, at 50/50 cotton/polyester blend samples, before treatment.

Fabric structure	Regression equation	Correlation coefficient
Plain weave 1/1	$Y = 0.43X + 20.80333$	-0.991682
Twill 2/2	$Y = 0.43X + 21.30667$	-0.978584
Satin 4	$Y = 0.765X + 30.93167$	-0.99854

### Roughness test

It is clear from the diagrams that satin weave is considered the most smooth fabrics among all woven fabrics followed by twill weave and then plain weave 1/1. This is probably because satin structure have the advantage of containing long floats and less intersections and so warp and weft threads float freely on both sides whereas plain weave has more intersections which increase its roughness.

From the results of roughness results and diagrams it is clear that, there is a direct relationship between weft set and roughness, as the more number of weft yarns per unit area the higher roughness the fabric become. This is due to the increased number of picks cause fabrics to be more compacted leading to a increase in fabric abrasion resistance higher leading to the increase in

roughness.

It is also obvious from results that cotton samples have achieved the lowest rates of roughness compared to 50/50 cotton/polyester blend samples. This is mainly due to that polyester yarns have a naturally regular cross section due to its serrated circular shape which resulted in a flat surface in the longitudinal view of the yarns, whereas the longitudinal view of cotton fibers show non uniform surface due to the presence of convolutions in the fibers which form a natural crimp texture to the fibers making their surface lower in smoothness compared to polyester yarns, but the differences were insignificant.

From the results of roughness test it is clear that treated samples have achieved the lowest rates of roughness compared to untreated samples. This is due to that coarse



**Table (10)** results of roughness and water absorption test applied to produced samples

The test No .	Roughness (Ra. $\mu$ m)		Water Absorption (sec.)	
	After treatment	Before treatment	Before treatment	After treatment
1	11.40	12.21	81	91
2	17.19	17.83	101	108
3	19.5	19.61	121	129
4	13.57	14.13	75	78
5	18.31	18.95	94	104
6	19.83	19.93	114	123
7	15.65	16.15	71	73
8	19.44	19.84	87	98
9	20.18	20.86	109	116
10	13.98	14.80	125	134
11	17.69	18.89	148	159
12	20.30	20.86	171	176
13	14.05	15.16	119	123
14	18.77	19.25	141	152
15	20.95	21.65	163	169
16	16.32	17.01	112	117
17	19.95	20.07	132	141
18	21.16	21.65	157	164

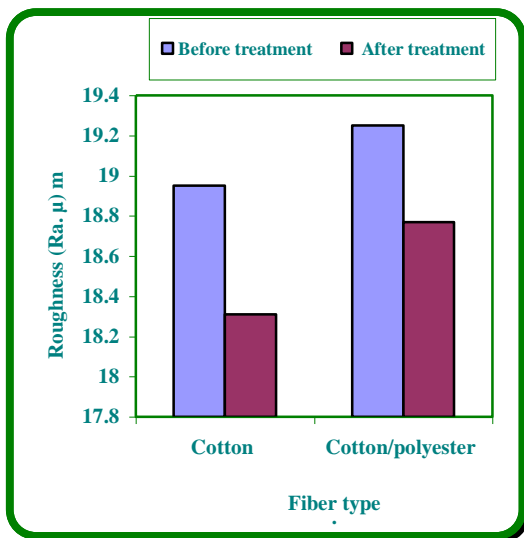

Fig .(11 ) Effect of fiber type on roughness after and before treatment , at blend samples and 27 picks/cm and twill 2/2.

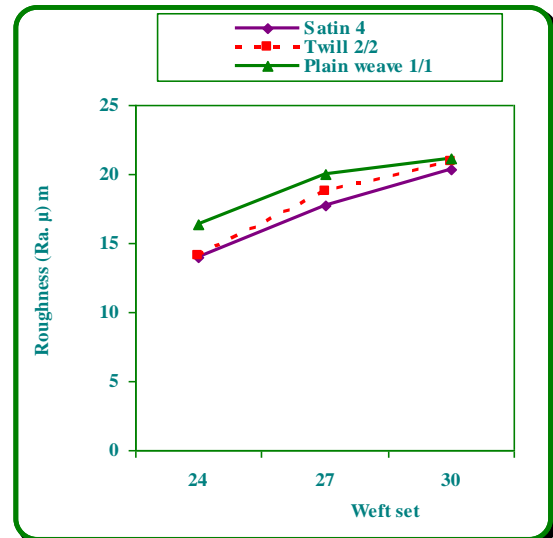

Fig .( 12) Effect of weft set and fabric structure on roughness after treatment, at 50/50 cotton/polyester blend samples

**Table (11)** Regression equation and correlation coefficient for the effect of weft set on roughness, at 50/50 cotton/polyester blend samples ,after treatment .

Fabric structure	Regression equation	Correlation coefficient
Plain weave 1/1	$Y=0.806667X-2.63667$	0.960769
Twill 2/2	$Y=1.15X-13.1267$	0.978153
Satin 4	$Y=1.05333X+11.1167$	0.994989

**Water absorption test**

It is obvious from results that 100% cotton samples have achieved the highest rates of absorption, whereas 50/50 cotton /polyester samples have achieved the lowest rates. This is due to that the molecular structure of cotton fibers have larger areas of amorphous regions (which is responsible for the higher water absorbency), whereas the molecular structure of polyester fibers have larger areas of crystalline regions so the absorbency of cotton fibers is (8.5% but polyester fibers is 0.4%).

It is also clear from pervious diagrams that samples of plain weave structure have recorded the highest rates of water absorbatation compared to samples of twill and satin weaves ,and this is because plain

weaves pores in fabric structure which allow the free passage of water through it.

It was also found that the more yarns per unit area the less absorbency the samples become, so samples with 30 picks per cm have recorded the lowest rates of water absorption, whereas samples with 24 picks per cm have recorded the highest rates (before treatment). This is due to that the increase of number of picks/cm causes the produced fabric to be more compacted and which decrease the free passage of water through it.

From tables and figures it can be seen that treated samples have decreased water absorption compared to untreated samples. Where it could be reported that treatment caused the pores in the structure to be blocked leading to the decrease in fabric absorbency.

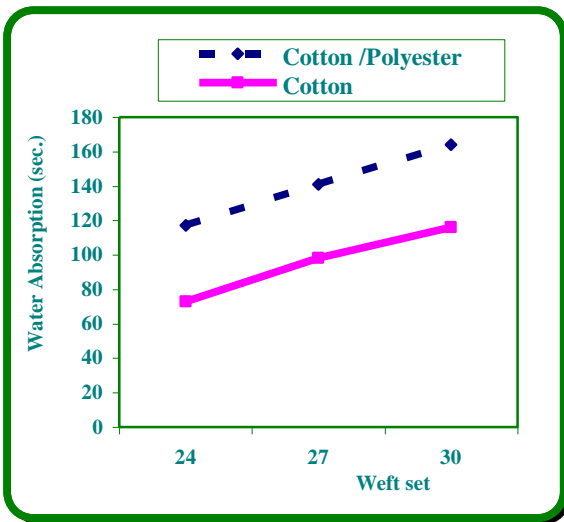

Fig .(13 ) Effect of fiber type and weft set after treatment ,at satin 4

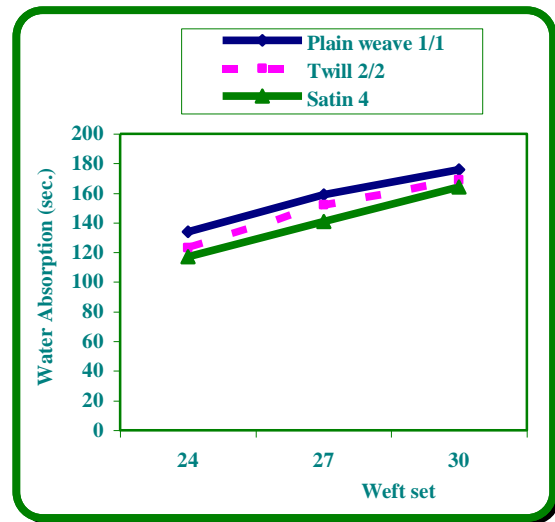

Fig .(14 ) Effect of weft set and fabric structure on water absorption after treatment , at 50/50 cotton/polyester blend samples.

**Table (12)** Regression equation and correlation coefficient for the effect of weft set on water absorption, at 50/50 cotton/polyester blend samples, after treatment.

Fabric structure	Regression equation	Correlation coefficient
Plain weave 1/1	$Y=7X-32.6667$	0.994007
Twill 2/2	$Y=7.6667X-59$	0.988847
Satin 4	$Y=7.83333X+70.8333$	0.999925

**Table (13)** Regression equation and correlation coefficient for the effect of weft set and fiber type on water absorption, at satin 4 , after treatment .

Fiber type	Regression equation	Correlation coefficient
Cotton	$Y=7.1667X-97.8333$	0.995612
Cotton /polyester 50/50	$Y=7.8333X-70.8333$	0.999925

**Table (14)** results of thickness and weight test applied to produced samples

The test No .	Thickness(mm)		Weight (g/m <sup>2</sup> )	
	Before treatment	After treatment	Before treatment	After treatment
1	0.45	0.52	184	206
2	0.48	0.56	199	224
3	0.54	0.60	211	231
4	0.49	0.55	187	215
5	0.52	0.58	205	230
6	0.56	0.62	212	235
7	0.64	0.71	191	220
8	0.68	0.78	207	228
9	0.70	0.81	213	239
10	0.44	0.48	185	211
11	0.47	0.50	193	228
12	0.49	0.53	202	239
13	0.51	0.55	190	219
14	0.54	0.59	203	232
15	0.58	0.63	204	245
16	0.53	0.57	193	222
17	0.56	0.59	208	237
18	0.59	0.63	215	248

### Thickness

It was also found that the more yarns per unit area the more thicker the samples become, so samples with 30 picks per cm have recorded the highest rates of thickness, whereas samples with 24 picks per cm have recorded the lowest rates. This is due to that the increase of number of picks/cm causes the produced fabric to be more compacted and then the thickness will be increased.

It is clear from the diagrams that, plain weave has recorded the highest rates of thickness, followed by twill weave, and then satin which

achieved the lowest rates. This is mainly for sake of that plain weave has ridges on fabric surface causing it to be thicker than other structures but it was found that the differences between them were insignificant.

It is also obvious from the results that treated samples have achieved higher thickness compared to non-treated samples. It can be reported that the treatment caused a increase in weight due to the strike – through of coating composition through the interstices of the fabric and so the fabrics become thicker compared to non-treated samples.

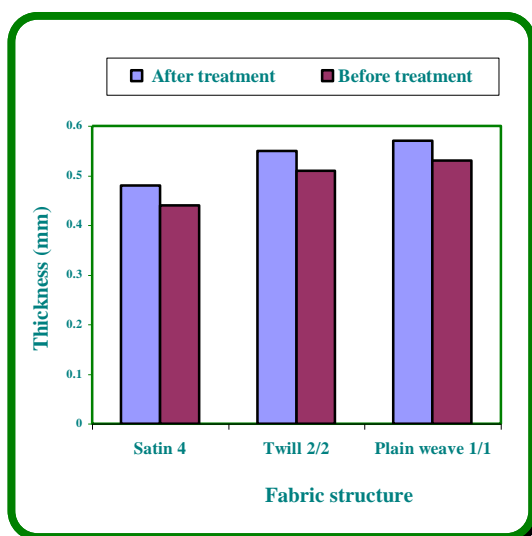

Fig.(15) effect of fabric structure on thickness, at 24 picks/cm and cotton samples, after and before treatment

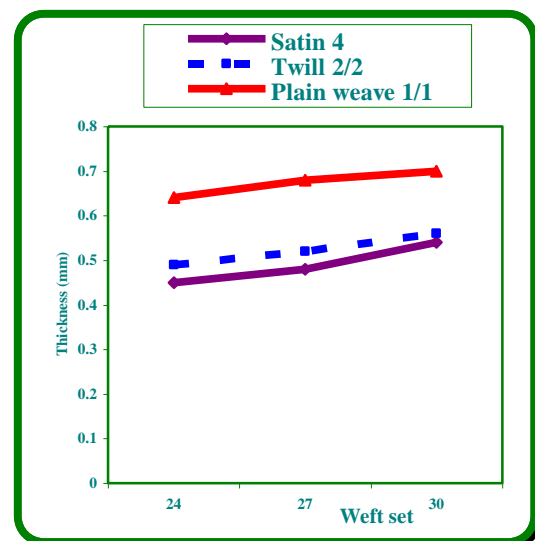

Fig.(16) effect of weft set and fabric structure on thickness, at 50/50 cotton/polyester blend samples., after treatment

**Table (15)** Regression equation and correlation coefficient for the effect of weft set and fabric structure on thickness, at 50/50 cotton/polyester blend samples , after treatment .

Fabric structure	Regression equation	Correlation coefficient
Plain weave 1/1	$Y=0.01X+0.40333$	0.981981
Twill 2/2	$Y=0.01167X+0.208333$	0.996616
Satin 4	$Y=0.015X+0.085$	0.981981

**Weight**

It is clear from the results, that satin weave has recorded the highest rates of weight, whereas samples with satin have achieved the lowest rates but that the difference was insignificant. It was also found that there is a direct relationship between number of picks per unit area and samples

weight. This is for the sake of that, the increase in number of picks cause fabrics to be more compacted because of the decrease in spaces between yarns leading to the increase in fabric weight.

It is clear from the results that the difference in weight between 100% cotton samples and 50/50 cotton /polyester samples was insignificant.

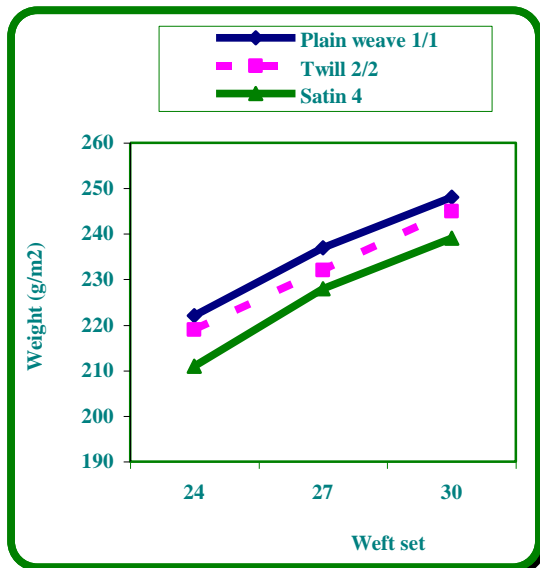

Fig.(17 ) effect of weft set and fabric structure on weight ,at 50/50 cotton/polyester blend samples, after treatment

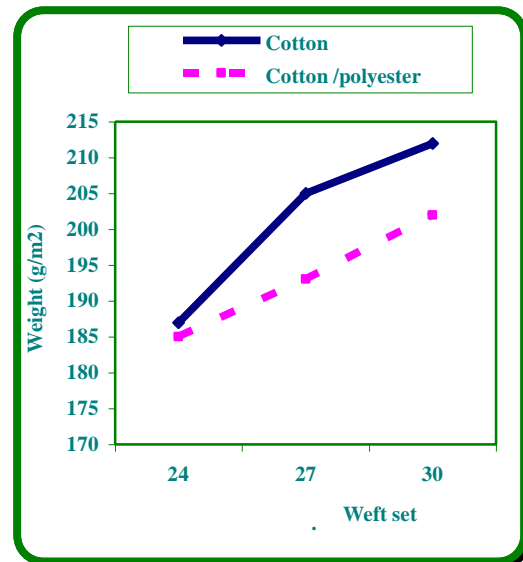

Fig.(18 ) effect of weft set and fiber type on weight ,before and after treatment

**Table (16)** Regression equation and correlation coefficient for the effect of weft set and fabric structure on weight, at 50/50 cotton/polyester blend samples , after treatment .

Fabric structure	Regression equation	Correlation coefficient
Plain weave 1/1	$Y=9.3333X+118.6667$	0.9960168
Twill 2/2	$Y=4.333X+115$	1
Satin 4	$Y=4.6667X+100$	0.992434

**Table (17)** Regression equation and correlation coefficient for the effect of weft set and fiber Type on weight, at twill 2/2 before treatment .

Fiber type	Regression equation	Correlation coefficient
Cotton	$Y=4.16667X+88.8333$	0.964216
Cotton /polyester 50/50	$Y=2.8333X+116.83333$	0.999424

**Knowledge**

The authors are grateful to Dr. **Rafat Hassan** the Professor in Textile printing, dyeing and preparation Dept.; Faculty of Applied Arts, Helwan University for his assistance and truly support during treatment part of the research.

Also the authors are grateful to **Dr. Mohamed Mohammed Hashem** Professor of Textile Chemistry and Technology, Department of Preparation and Finishing of Cellulosic Fibers (Head Department of Textile Division), National Research Centre for his encouragement and truly support during tests.

**Corresponding author**

Ibrahim, G. E

Spinning, Weaving & Knitting Department, Faculty of Applied Arts, Helwan University, Cairo, Egypt

Home Economic, Faculty of Education – Zilfi, AL-Majma'ah University

**References**

1. Bajaj, P., and Sengupta, A., K., " Protective Clothing", Textile Progress, vol.22,no.2/3/4,1992.p1,85&89
2. Hira, M., A., "Fire- Resistant Clothing and its Performance Testing", The Indian Textile Journal, July, 2003.p39
3. Adanur, S., "Wellington Sears Handbook of Industrial Textiles", Technomic Publishing Company Inc., Lancaster, Pennsylvania, 1995.p415, 449&450
4. Raheel, M., " Protective Clothing: An Overview", Protective Clothing Systems And Materials, 1<sup>st</sup> edition, Marcel Dekker, Inc., New York, 1994.p1
5. Gibson, P., Barry, J., and others," Computational Fluid Dynamic Modeling of Protective Clothing System", 43<sup>rd</sup> International Man-Made Fibers Congress 2004, Dornbirn, Technical Textiles,vol.47, Aug.,2004.p124
6. Fuchs, H.,and Haase, J., " Overview of Protective Clothing Types Against Thermal and Electric Risks".Technical Textiles, vol.41, Nov., 1998.:60
7. Raheel, M., "Chemical Protective Clothing", Protective Clothing Systems And Materials, 1<sup>st</sup> edition, Marcel Dekker, Inc., New York, 1994.p39-53
8. Smith, W., C.," Protective Clothing in the US". Textile Asia, Sept., 1989.p193
9. Sen,A.,K.,"Coated Fabrics, Principles & Applications", 1st edition, Technomic Publishing Company Inc.,2001.p187
10. Billing, C., B., and Bentz, A., P., "Effect of Temperature, Material Thickness, and Experimental Apparatus on Permeation Measurement, Performance of Protective Clothing", ASTM STP 989. American Society for Testing and Materials, Philadelphia, 1988.....p257-268
11. Salz, P.,"Testing the Quality of Breathable Textiles". Performance of Protective Clothing, 2<sup>nd</sup> Symposium, 1988.p295
12. Dartman, T., "Predictions of Performance Characteristics of Coated Fabrics". Technical Textiles, vol. Nov., 1995. 38:43
13. Gore, R., W., and Allen, S., B., "Waterproof Laminate", U.S. Patent, no.4194041, Mar.18, 1980.p1
14. ISO 6350/EN368 gutter method for measuring protection against hazardous chemical liquids.
15. AATCC (1700a) Standard test method for measuring for determining the roughness, (1700a)
16. ISO 811: 1981, Standard test method for measuring water absorption of textile materials.
17. ASTM-D1682, Standard test method for measuring tensile strength and elongation at break.
18. ASTM-D1777/1996, Standard test method for measuring fabric thickness.
19. ASTM-D 3776- 79, Standard test method for measuring fabric weight of textile materials.